



1,200 LB  
OUR CARTS  
HAUL  
MORE

PROUDLY  
MADE IN THE  
USA

BUILT  
HEAVY DUTY  
TO OUTLAST  
OTHERS

3yr  
THREE  
YEAR  
LIMITED  
WARRANTY

The largest capacity in its class; built specifically for transporting inflatables and other oversized items.

## FEATURES

- 13" Pneumatic front wheels for rough terrain
- 10" Flat free rear swivel wheels with steel hubs
- Welded one piece steel frame
- E-Track ratchet system (See pg 11 for E-Track straps)
- Folding, adjustable foot plate

## STANDARD AMERICAN CART FEATURES

- **Made in the USA**  
Hand crafted at our Ohio plant.
- **Heavy-duty comes standard**  
American Carts are all built to heavy duty specs
- **Powder coated finish**  
Protects the steel and provides a lasting finish
- **Steel construction**  
Built from American sourced steel
- **D-Brackets**  
One piece design supports the axle and load better than the competition
- **3/4" Axle**  
Industry leading axle size for maximum strength.
- **Easy to operate**  
Designed to get work done with less muscle strain and simple operation.
- **Ready to ship**  
in stock and ready to ship
- **Three Year Limited Warranty**



Adjustable wheel position.

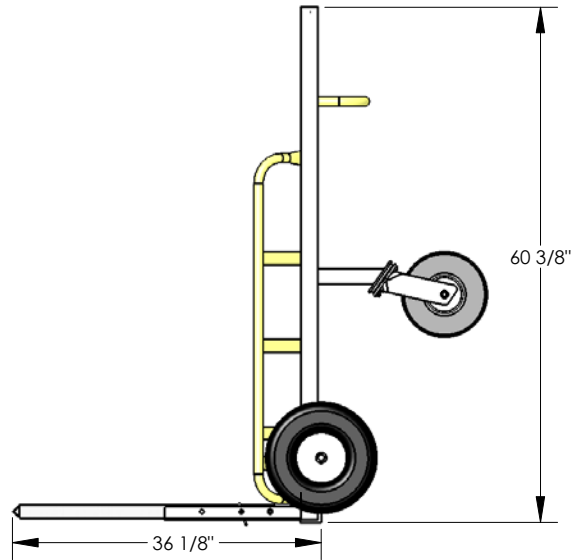
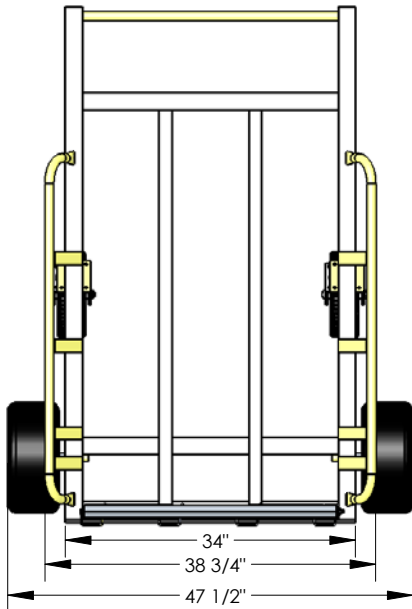

<b>Dimensions:*</b>	<b>W:</b> 47"	<b>D:</b> 70"	<b>H:</b> 38"
<b>Foot Plate:</b>	<b>W:</b> 30"	<b>D:</b> 34"	
<b>Weight:</b>	145 lbs.	<b>Capacity:</b>	1200 lbs.
<b>Typically Ships:</b>	Freight; fully assembled		

\*Measurements taken on 4 wheels with folding foot plate open